

THE INFORMATION CONTAINED IN THIS DRAWING IS THE SOLE PROPERTY OF NATIONAL PRODUCTS INC. ANY REPRODUCTION IN PART OR WHOLE WITHOUT THE WRITTEN PERMISSION OF NATIONAL PRODUCTS INC. IS PROHIBITED.

REV.	DESCRIPTION	REVISIONS	DATE	APPROVED

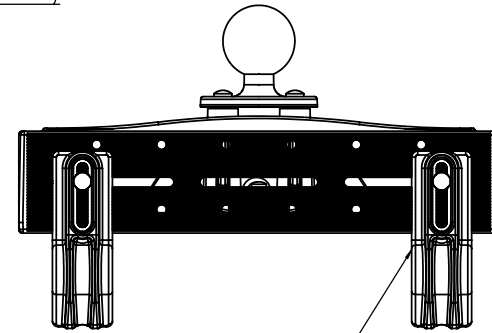

ADJUSTABLE UP AND DOWN PLUS SIDE ARMS MAY BE SECURED IN ANY POSITION ALONG SIDES OF TRAY
 USE 3 OR 4 SIDE ARMS TO SECURE LAPTOP AND AVOID ACCESS AREAS OF LAPTOP DEVICE

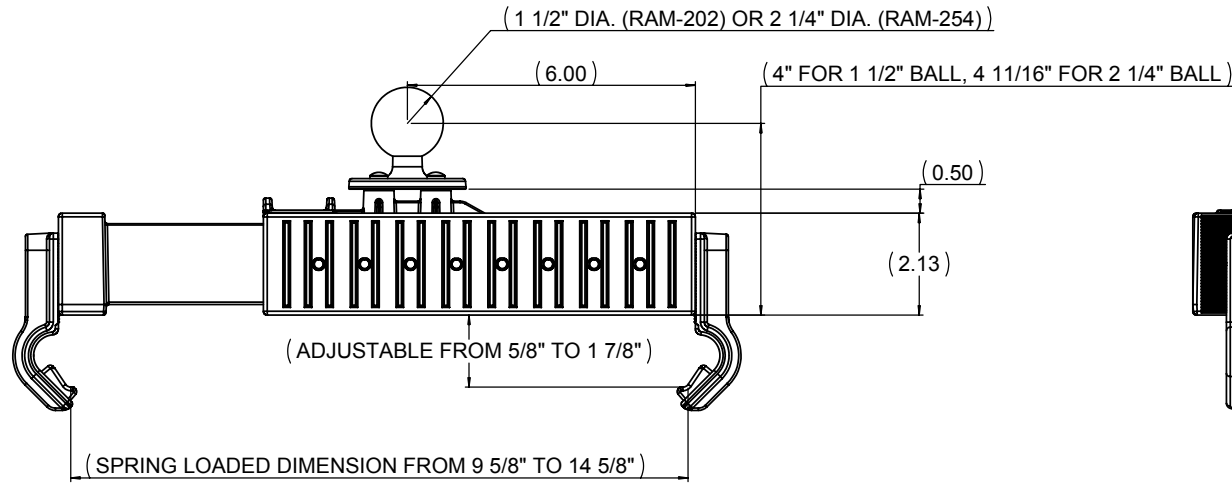
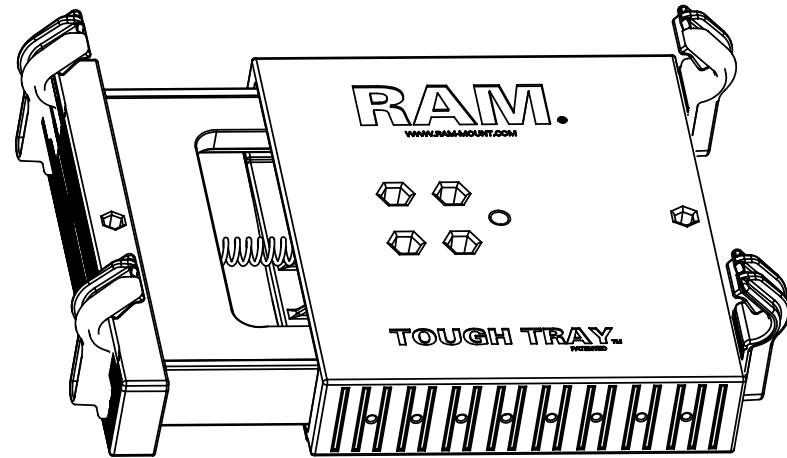
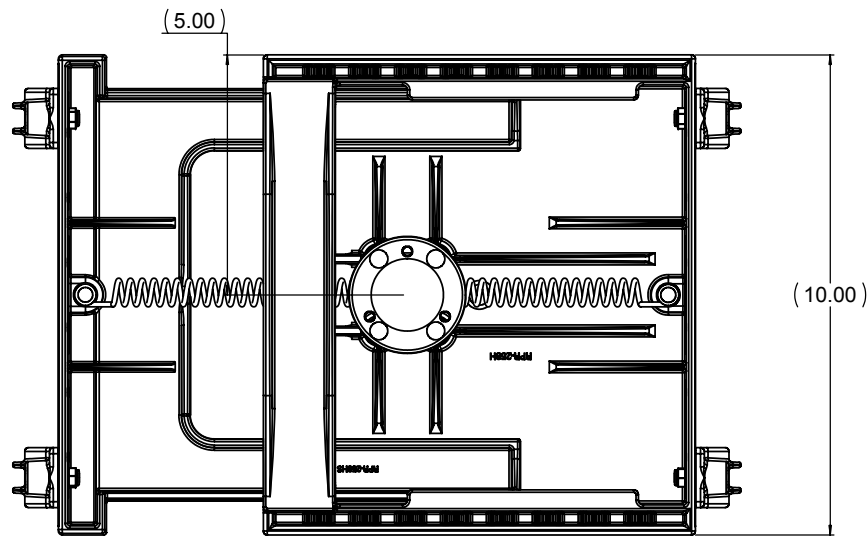

UNLESS OTHERWISE SPECIFIED DIMENSIONS ARE IN INCHES TOLERANCES ARE: FRACTIONS DECIMALS ANGLES +/- 1/32 .XX+ .03 +/- 1 DEG. .XXX+ .010	C-AD GENERATED DRAWING. DO NOT MANUALLY UPDATE		NATIONAL PRODUCTS INC.	
	APPROVALS	DATE	RAM UNIVERSAL LAPTOP COMPUTER TRAY	
MATERIAL PLASTIC	DRAWN JDC	05/20/02	SIZE C	REV.
FINISH BLACK	CHECKED CMR	05/20/02	DRWG. NO. RAM-234-3	SCALE 1 TO 1
DO NOT SCALE DRAWING	RESP ENG	QUAL ENG	CAD FILE: RAMZ343	SHEET 1 OF 1